

## FULL

### Features

- ◆ Capable of Slicing up to 1,000 Loaves per Hour
- ◆ Stainless Steel Chute with Built-In Last Loaf Pusher
- ◆ Heavy-Duty Welded Steel Construction
- ◆ Twin Crumb Collecting Trays, 8.72 Gallon Capacity Each
- ◆ Adjustable Bread Hold Down System Accommodates Various Bread Heights
- ◆ Available Double Loaf Loading Ramp and Discharge Belts, Optional
- ◆ Bag Opening Blowing Device Folds Away for Easy Storage
- ◆ Heavy Duty Castors, Two Locking



### High Output Slicer Ideal for Two Users

Easy to load and extremely reliable, this fully automatic, semi-industrial bread slicer is capable of cutting up to 1,000 loaves per hour. The optional high-capacity loading ramp features side guides and guide shoes for worry-free operation. With the addition of a 23.6" discharge belt and an ingenious rotating bagging spade, you'll be slicing and bagging bread faster and more efficiently than ever before! This makes the FULL Bread Slicer a quality investment for your highly-demanding application.

FEATURES	
Max. Loaf Dim. (L x H) (in inches)	20.5 X 6.3
Power Output (in kW)	0.75
Net Weight (in Lbs.)	814
Air Blowing System	included
CHOICE OF	
Slice Thickness (in inches)	from 0.43 to 0.63
Loaf Height	normal
Type of Motor 110/240V	single or three-phases
OPTION	
Loading Ramp	•
Discharge Belt (instead of air blowing system)	•
Carousel	•

**NOTE:** Specifications are subject to revision and confirmation.

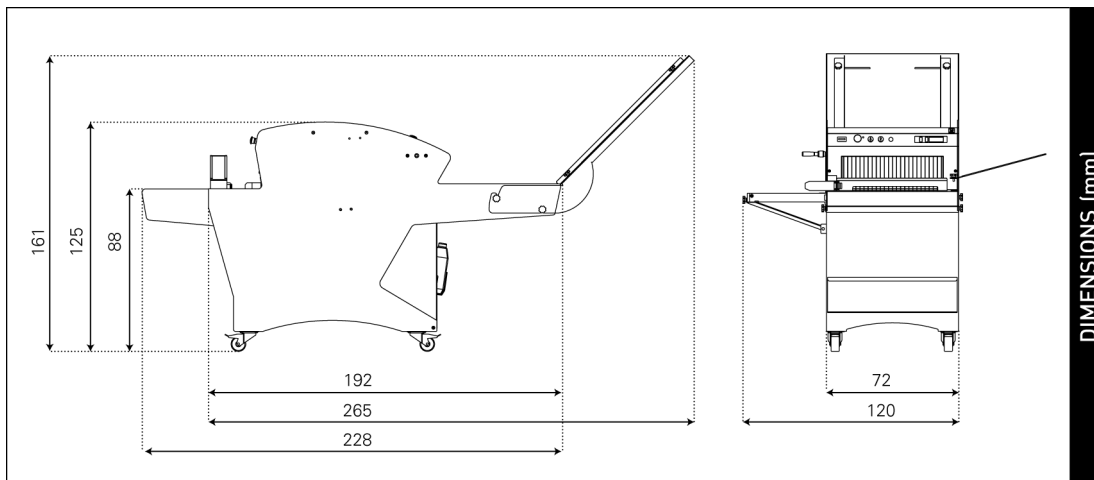

Easy to access drawer containing two durable, 8.72 gallon bins for crumb collection.



High-capacity ramp featuring side guides and shoes. Used to store and deliver loaves to the slicer.



This ingenious rotating bagging spade system will allow you to pack several loaves quickly.



Replace the delivery table and air-blown bagging system with an optional 23.6 inch discharge belt