

## PSA-1/PSA-2

### Load and Unload Your Deck Oven With Ease!

Empire PSA Oven Loaders, available in semi-automatic and fully automatic models, are the perfect compliment to our complete line of stone hearth deck ovens. The **Semi-Automatic PSA-1** utilizes an advanced counterweight system to raise and lower the mechanism smoothly, while the **Fully Automatic PSA-2** features state-of-the-art motorized lifting controls to maneuver at the push of a button. Both models eliminate the need for hand peels and manual setters, making the loading and unloading of breads, rolls and pan goods a snap. When you need to increase the efficiency and productivity of your oven, count on an **Empire PSA Oven Loader!**



### Features

- ◆ Simplifies oven loading *and unloading*.
- ◆ Perfect for breads, rolls and pan goods.
- ◆ Fits all LF, LFK and LFKR oven models.
- ◆ Eliminates the need for hand peels and manual loaders.
- ◆ Powered in-and-out operation.
- ◆ Precision balanced counterweight lifting system. (PSA-1)
- ◆ Motorized lifting system with push button control. (PSA-2)

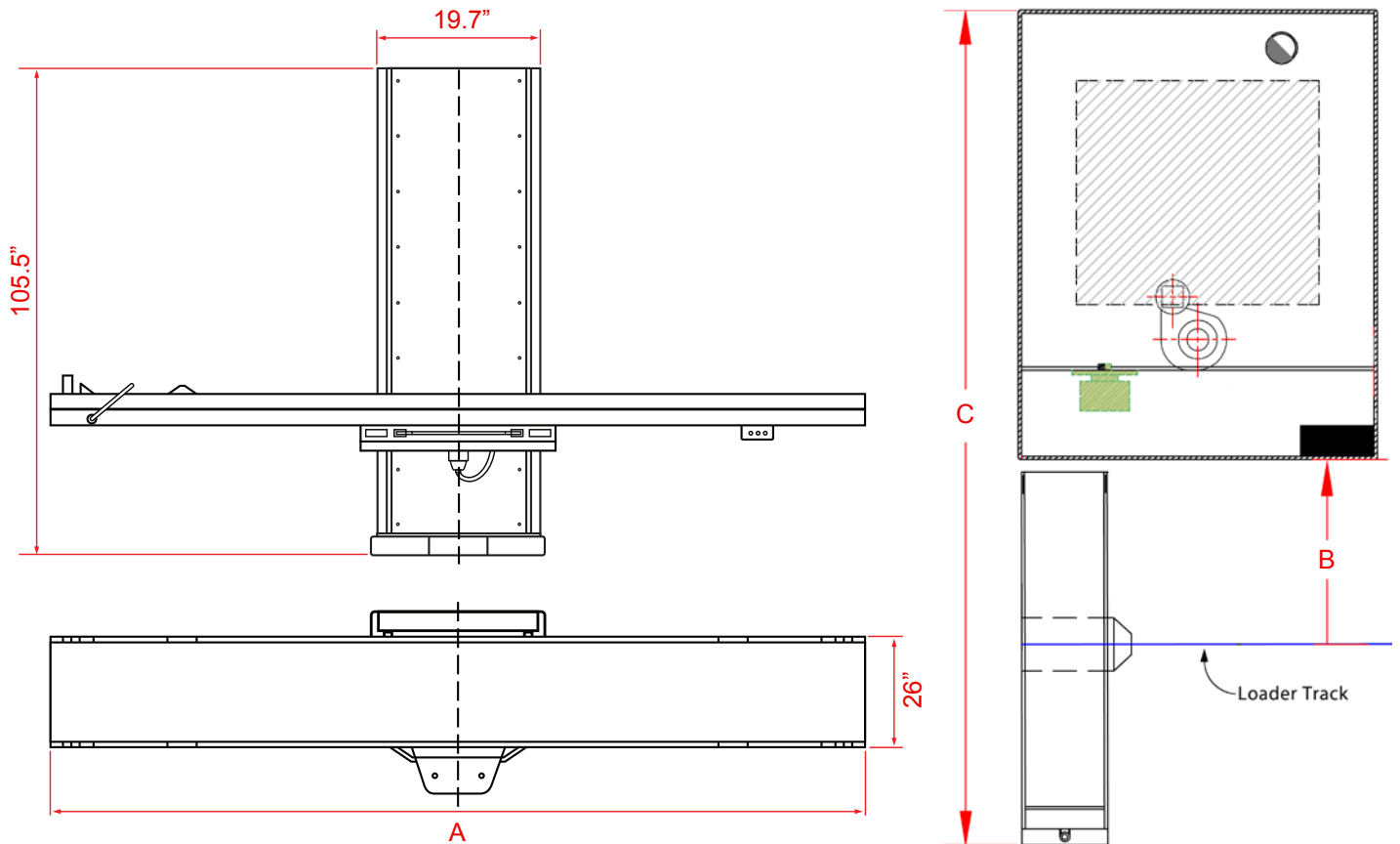

Oven Models	Oven Deck Depth	Overall Loader Length (A)	Track Distance from Oven (B)	Overall Length (C)	Specifications
	in.	in.	in.	in.	
<b>LF / LFK / LFKR*</b>  *Please refer to the oven cut sheets for specific model information and sizing details.	63"	113.2"	58.1"	233.3"	<b>Belt Width:</b> 22"  <b>Electrical (PSA-1):</b> 220V / 3 Phase / 60 Hz 2.8 Amp Service  <b>Electrical (PSA-2):</b> 220V / 3 Phase / 60 Hz 5 Amp Service  <b>Connection:</b> Suggested installation requires a separate and dedicated circuit for loader installation. All installations must adhere to all applicable codes.
	77.6" - 78.7"	127.8"	65.4"	262.4" - 263.3"	
	86.2"	136.4"	69.7"	279.7"	
	94.5" - 94.9"	145.1"	74.0"	297.0" - 297.4"	
	103.5"	153.7"	78.3"	314.4"	
	112.2"	162.4"	82.7"	331.7"	
	116.5"	166.7"	84.8"	340.4"	
125.2"	175.4"	89.2"	357.7"		

**NOTE:** Specifications are subject to revision and confirmation.