

NEW SELF

Features

- ◆ Safe and Easy to Use for Customers and Bakers
- ◆ Perfect for Supermarkets, Bakeries, and Foodservice Locations
- ◆ Locking In-feed Lid for Safety and Security
- ◆ Compact Size Will Fit Nicely in Tight Spaces
- ◆ Heavy-Duty Frames & Individual Tensioning Blades
- ◆ Quiet, Reliable, Trouble Free Operation
- ◆ Large Crumb Tray
- ◆ Supplied with Top Mounted Bagging Spade
- ◆ Heavy-Duty Castors, Two Locking



The First Choice for Supermarkets

The NEW SELF Bread Slicer pioneers a new approach to customer satisfaction. Safety, self-service and user-friendliness are this slicers main objectives. Designed to offer both the bakery operator and the customer a risk-free and reliable slicing experience, the NEW SELF Bread Slicer is a must have for your bakery department!

	NEW SELF 450	NEW SELF 600 DUAL	NEW SELF 450M
FEATURES			
Max. Loaf Dim. (L x W x H) (in inches)	17.3 x 12.6 x 6.3	11.8 x 12.6 x 6.3 (2 loaves)	17.3 x 12.2 x 6.3
Power Output (in kW)	0.55	0.55	1.1
Net Weight (in Lbs.)	462	594	484
CHOICE OF			
Slice Thickness (in inches)	0.31 to 0.63	0.43 to 0.63	0.35 to 0.43
Loaf Height	Low, Normal, High	Low, Normal, High	Normal
Type of Motor 110/240V	single or three-phases	single or three-phases	three-phases

NOTE: Specifications are subject to revision and confirmation.

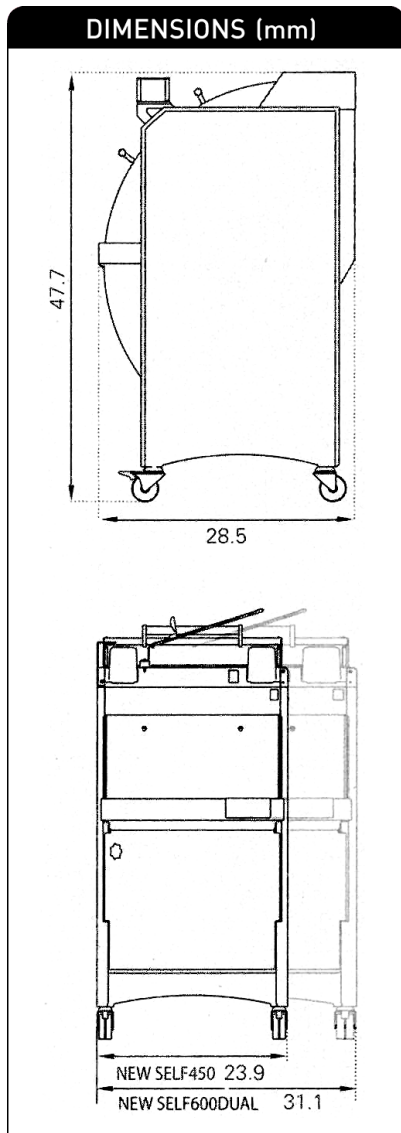

1. Open the cover



2. Load bread.



3. Close the cover, slicing will start automatically.



4. Flap opens to indicate slicing is complete.



5. Remove the bread, the flap closes automatically.



6. Pack the bread using the bagging spade.