

Single Bank / EMP1-2A

World's Favorite Bagel Machine

The Empire Automatic Bagel Machine is time proven. It's fast, strong, reliable and is easily adapted for the production of mini, regular and bull bagels at up to 3,600 pieces per hour. The divider has a scaling range of 1 to 12 ounces and may be used independently to divide many types and textures of dough. Our variable knife speed assures you of the proper dough piece shape for all sizes and weights of your product. The bagel former is designed to work in conjunction with the divider, but may also be hand fed.



Features

- Produces up to 3,600 Pieces/Hour
- Variable Speed on Knife Allows you to Adjust Dough Piece Shape for the Best Possible End Product
- Rotary Knife Action - No Piston or Messy Oil Clean Up
- 20 Inch Turntable for Easy Accessibility and Panning
- No Heat Transfer from Machine to Dough
- Easily Adjusted Pressure Plate
- Knife is Teflon Coated (No Oiling Necessary)
- Mounted on Casters for Easy Movement & Cleaning
- 4 Foot Infeed Conveyor for High Capacity
- Cutaway Frame Allows Easy Clean-Up

EMP1-2A Technical Data

Model	Weight	Electrical		
		Voltage	HP	Amps
Dough Divider - EMP1	550 lbs.	208/220V-60 Cy-3PH	1/2	2.2
Bagel Former - EMP2A*	300 lbs.		1 1/2	4.6

*EMP2A bagel former available as single phase on special order only.



4/2/03

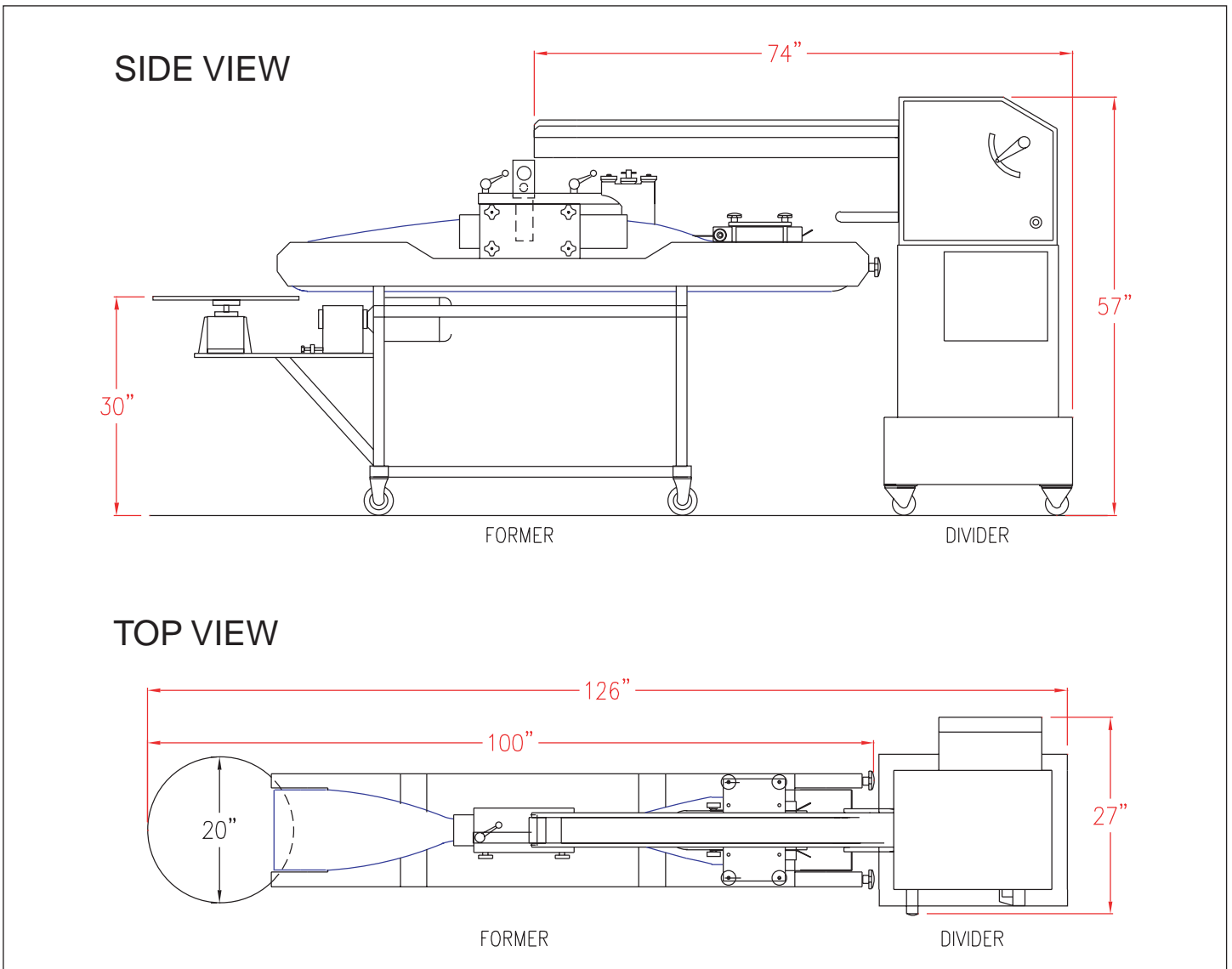

NOTE: Specifications are subject to revision and confirmation.

SBBM.02



1 C Enterprise Place, Hicksville, NY 11801-5356 ■ ph: 516-681-1500 ■ fx: 516-681-1510
 1-800-878-4070 ■ www.empirebake.com ■ email: info@empirebake.com