



UNIC

Features

- ◆ Output up to 1,200 Loaves per Hour
- ◆ Weight Range: 2-42 Ounces
- ◆ Sheeting Thickness: 1/16-5/8 Inch
- ◆ Front Roller Cover Safety Guard
- ◆ Precise Roller and Belt Adjustment
- ◆ Easily Removable Belts
- ◆ Foldaway Delivery Tray
- ◆ Memo Board for Settings
- ◆ Heavy-Duty Frame & Construction
- ◆ Optional Base with Casters Available



French Bread Moulder

Perfect for the production of baguettes, finger rolls, long-loaves, petit pans, hot dogs and various other sized breads. The UNIC sheets through a series of three rollers and the progressive extension of the loaf is accomplished between two conveyor belts running in the opposite direction at varying speeds. This allows for gentle dough handling and a 'hand-made' effect. The belt housings on the UNIC can be quickly disassembled via the specially designed hatches making cleaning and maintenance a breeze, and the delivery tray folds away completely to facilitate easy storage.

FEATURES	
Weight of Dough Pieces (in oz.) - min/max	2/42
Maximum Production Rate	1200/hr
Power Output Three-Phase 208/240 (in kW)	1.1
Net Weight (in lbs.)	463
OPTIONS	
Stainless Steel Cladding	•
Base with Casters (height - 34.7")	•
Feed Belt	•
Delivery Belt	•
Belt with Tapered Ends	•
Side Guides	•
Secured Chute	•

NOTE: Specifications are subject to revision and confirmation.

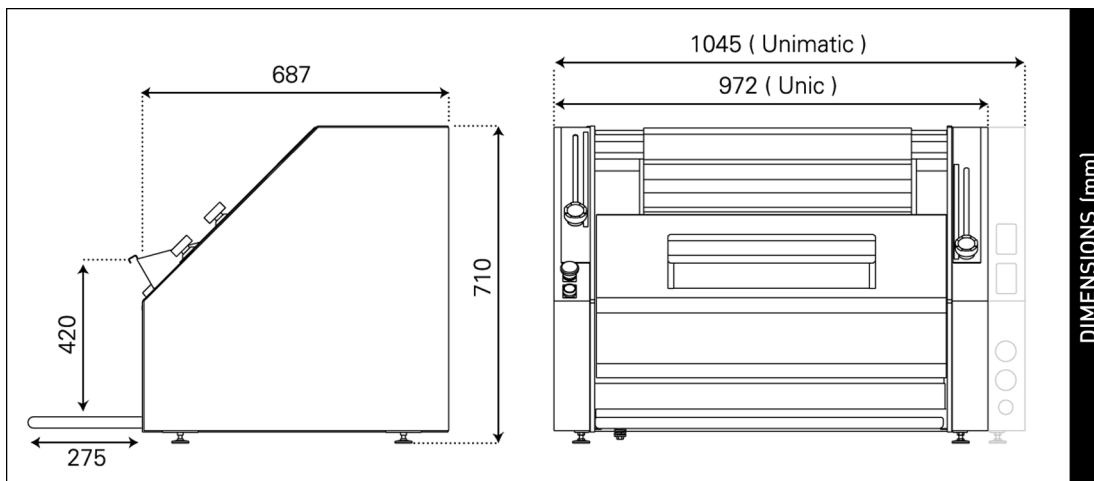

Mould breads from 2-42 ounces, including baguettes up to 27.6" wide.



Easily remove belts for worry-free cleaning and maintenance.



Tuck away the foldaway delivery tray completely to facilitate storage.



Write down your per bread settings on the laminated memo board.