

## SPT/3

### Full Featured Dough Sheeting

The SPT/3 Sheeter is the durable and economic solution to your dough sheeting needs. Its rugged construction and simple design ensure years of trouble-free performance.

Differential belt speeds, large diameter rollers and large dough capacity will provide you with high quality, high production dough sheeting in a minimal space. The SPT/3 represents the highest value and quality available.



### Features

- ◆ 3.3" Diameter Sheeting Rollers
- ◆ 1.7" Maximum Roller Opening
- ◆ High Sheeting Capacity (up to 22 lbs. of dough)
- ◆ Compact Design (tables fold up for storage)
- ◆ Synthetic Fabric Belts - 23.5" W x 55" L
- ◆ Lever Operated Reversing Belts
- ◆ Mounted on Casters for Easy Mobility
- ◆ Flour Holder Built into Machine Casting
- ◆ Rolling Pins and Supports Included

Model	Overall Machine Dimensions (in inches)				Net Weight
	Length (with pans extended) A	Length (without pans) B	Depth C	Height D	
SPT/3	131	110	42	54	463 lbs.
Electrical	220V / 60HZ / 3PH, 1 hp				

10/14/03

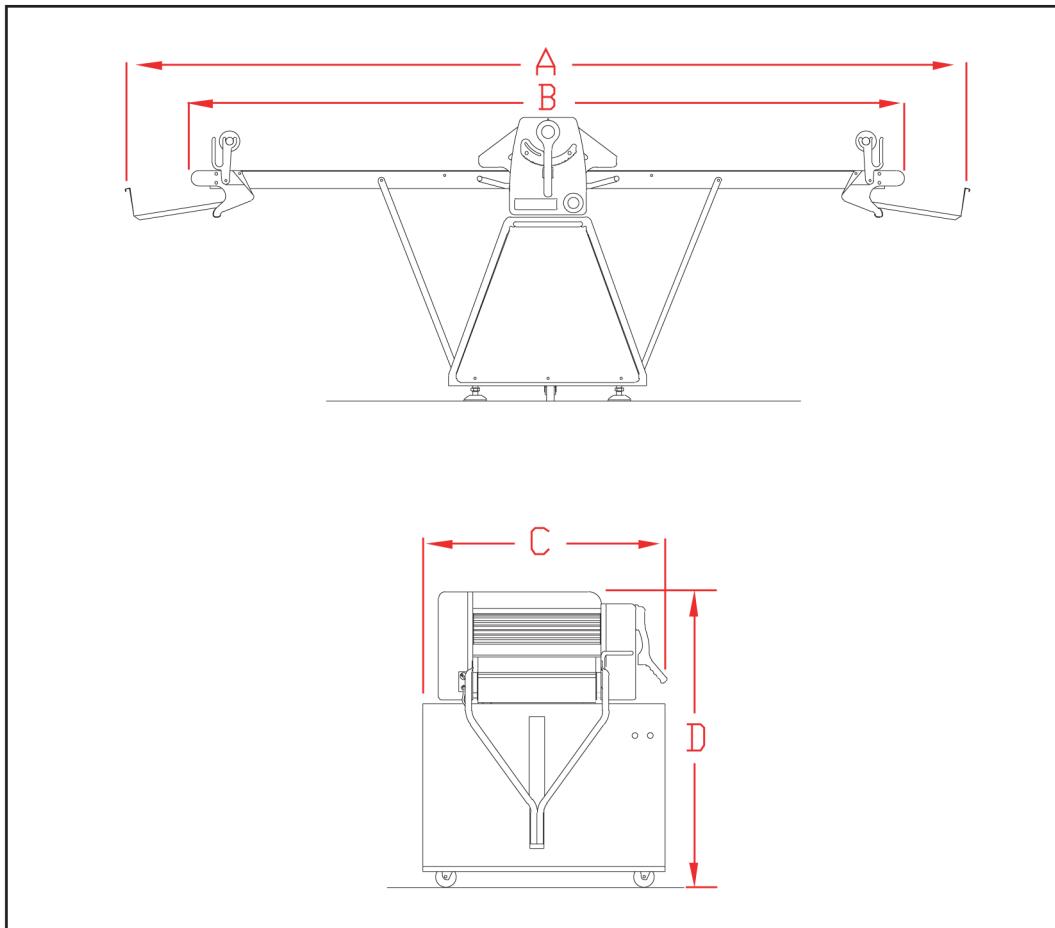

**NOTE:** Specifications are subject to revision and confirmation.