

SPT/3

## Full Featured Dough Sheeting

The SPT/3 Sheeter is the durable and economic solution to your dough sheeting needs. Its rugged construction and simple design ensure years of trouble-free performance.

Differential belt speeds, large diameter rollers and large dough capacity will provide you with high quality, high production dough sheeting in a minimal space. The SPT/3 represents the highest value and quality available.



## Features

- 3.3" Diameter Sheeting Rollers
- 1.7" Maximum Roller Opening
- High Sheeting Capacity (up to 22 lbs. of dough)
- Compact Design (tables fold up for storage)
- Synthetic Fabric Belts - 23.5" W x 55" L
- Lever Operated Reversing Belts
- Mounted on Casters for Easy Mobility
- Flour Holder Built into Machine Casting
- Rolling Pins and Supports Included

# SPT/3 Technical Data

Overall Machine Dimensions (in inches)					
	Length (with pans extended) <b>A</b>	Length (without pans) <b>B</b>	Depth <b>C</b>	Height <b>D</b>	Net Weight
Model					
SPT/3	131	110	42	54	463 lbs.
Electrical	208-220V / 60HZ / 3PH, 1 hp (240V by special order)				

9/25/06

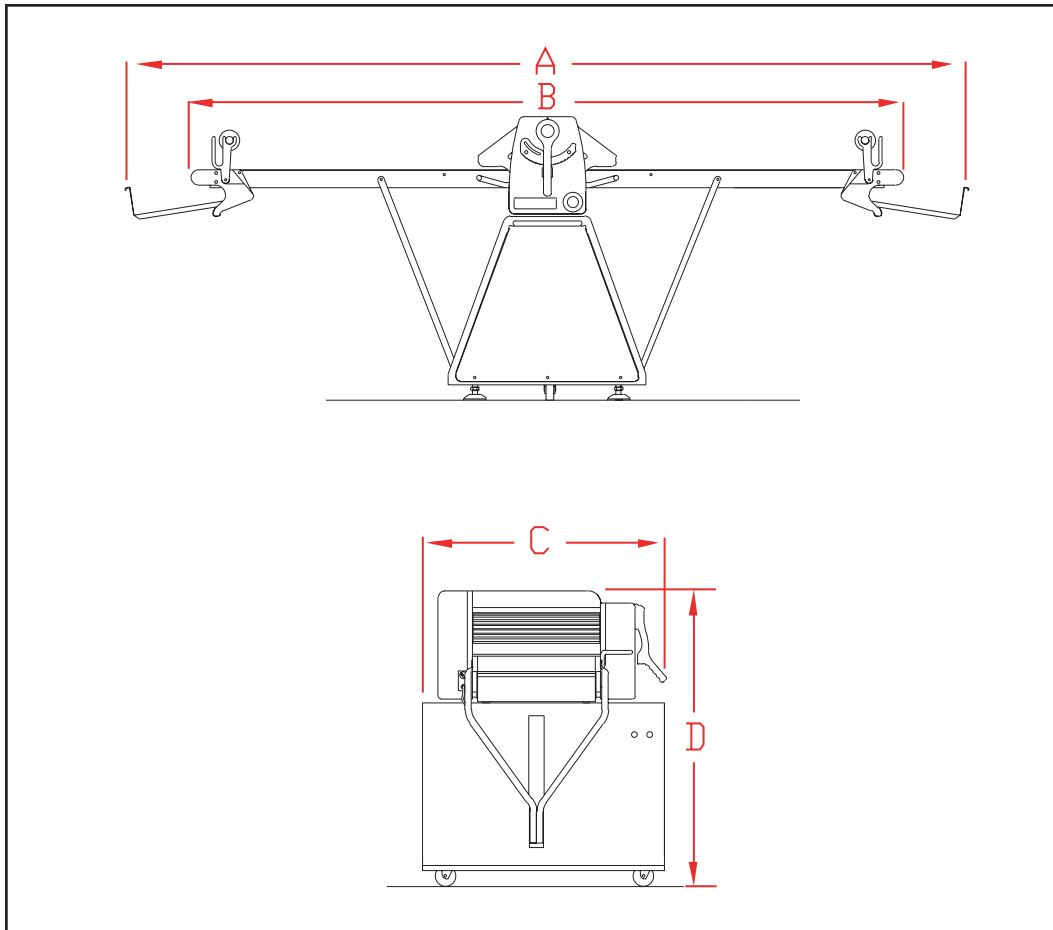

**NOTE:** Specifications are subject to revision and confirmation.

EMP-SPT3/E.04



1 C Enterprise Place, Hicksville, NY 11801-5356 ■ ph: 516-681-1500 ■ fx: 516-681-1510  
**1-800-878-4070** ■ [www.empirebake.com](http://www.empirebake.com) ■ [email: info@empirebake.com](mailto:info@empirebake.com)