

Stationary Bowl

Features

- 2-Speed Spiral and Bowl Drive
- Reversible Bowl Rotation
- Two Timers with Automatic Changeover from Low to High Speed
- Hi-Speed Lock Out Switch to Prevent High Speed Operation
- Stainless Steel Bowl, Spiral Arm, Breaker Bar and Guard
- See-thru Bowl Guard with Safety Interlock Prevents Operation with Guard Open
- Belt Driven Arm and Bowl for Quiet Operation and Low Maintenance
- Mounted on Three Casters for Easy Mobility and Cleaning



America's #1 Spiral Mixer

Strong enough for bagels, gentle enough for artisan dough, Empire Stationary Bowl Spiral Mixers are available in a wide range of sizes, and can mix from 20 to 560 lbs. of dough. Coordinated 2-speed spiral and bowl rotation gives maximum control of ingredient blending, dough development and better end product. Exclusive features, advanced engineering and rugged construction mean:

- **Maximum Versatility**
- **Precise Mixing Control and Consistency**
- **Higher Output**
- **Faster Mixing Time**

The #1 choice of bakers from coast to coast...you can count on it's quality and reliability!

Stationary Bowl Technical Data

All Models 220V 3 Phase 60 cycle
(Other voltages available)

Model	Capacity*		Overall**			Bowl			Weight (lbs.)	Electrical		
	Breads	Bagels	Width (with bowl)	Depth	Height	Width	Height	Top of Bowl to Floor		HP		Amps
	Flour/Dough	Flour/Dough	A	B	C	D	E	F		Spiral	Total	
60	75/120	60/88	25	39	46	24	14	33	800	5.5	5.7	16.9
80	100/160	80/118	29	43	48	28	14	33	858	6	6.75	19.4
100	130/208	100/148	29	43	48	28	16	35	924	7	7.75	22.5
130	150/240	120/178	33	54	51	31	17	35	1309	8	10.7	30.3
160	200/320	150/220	37	61	55	35	17	35	1550	14	16.7	47.3
200	250/400	200/296	37	61	55	35	19	36	1585	14	16.7	47.3
250	300/480	250/370	41	64	55	39	18	36	1804	14	16.7	47.3
300	350/560	300/444	44	68	55	43	20	38	1892	20	22.7	61.6

Dimensions in inches

6/8/2007

***NOTE:** Mixers used for bagel dough are rated at low speed only.
Operation at high speed will result in lower capacity and void the warranty.



****Machine width with bowl removed does not exceed 33" (for entry through 36" doorway).**

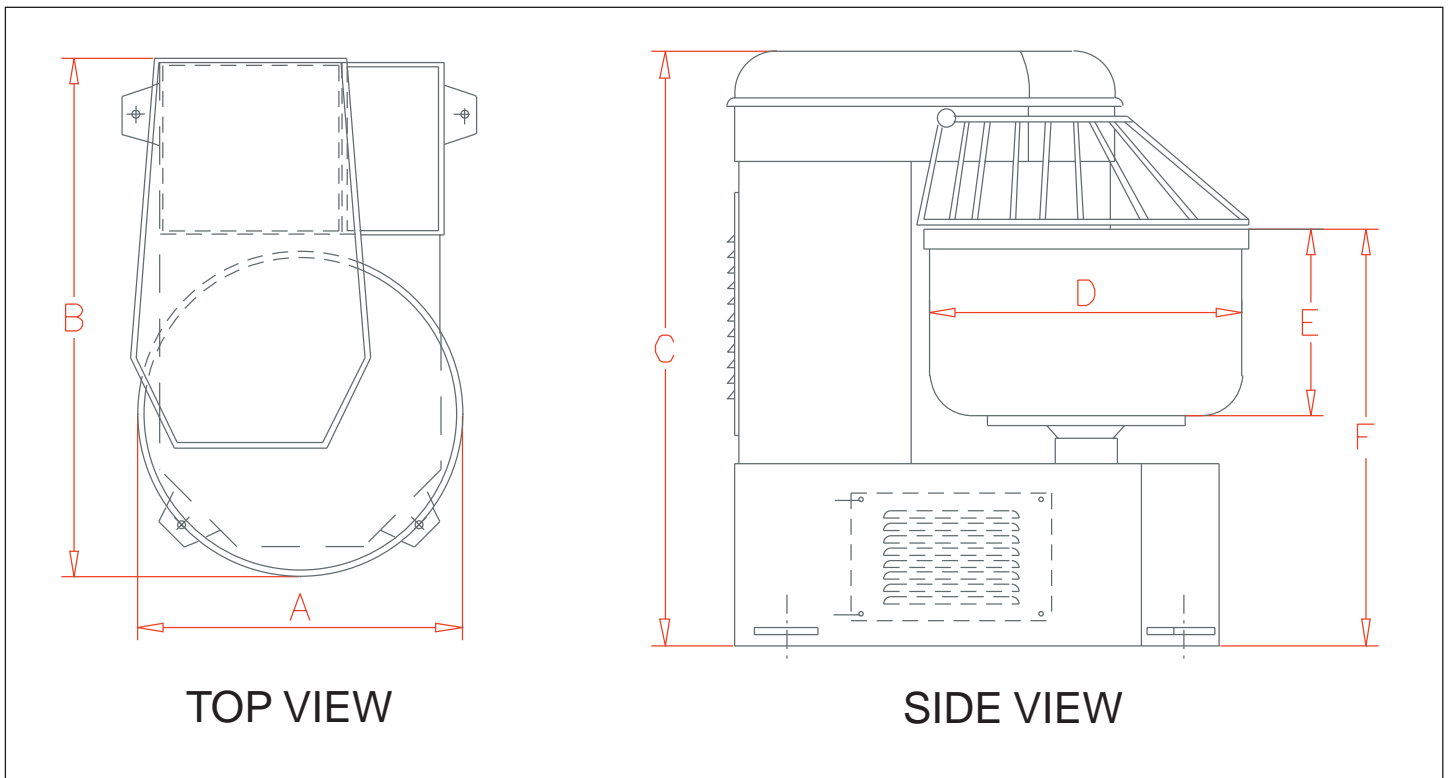

NOTE: Specifications are subject to revision and confirmation.

SBSM.05



1 C Enterprise Place, Hicksville, NY 11801-5356 ■ ph: 516-681-1500 ■ fx: 516-681-1510
1-800-878-4070 ■ www.empirebake.com ■ [email: info@empirebake.com](mailto:info@empirebake.com)