

## MASTER MIX

### Features

- ◆ 2-Speed Spiral and Bowl Drive
- ◆ Reversible Bowl Rotation
- ◆ Two Timers with Automatic Changeover from Low to High Speed
- ◆ Hi-Speed Lock Out Switch to Prevent High Speed Operation
- ◆ Stainless Steel Bowl, Spiral Arm, Breaker Bar and Guard
- ◆ See-thru Bowl Guard with Safety Interlock Prevents Operation with Guard Open
- ◆ Belt Driven Arm and Bowl for Quiet Operation and Low Maintenance
- ◆ Mounted on Three Casters for Easy Mobility and Cleaning



### America's #1 Spiral Mixer

Strong enough for bagels, gentle enough for artisan dough, Empire Stationary Bowl Spiral Mixers are available in a wide range of sizes, and can mix from 20 to 560 lbs. of dough. Coordinated 2-speed spiral and bowl rotation gives maximum control of ingredient blending, dough development and better end product. Exclusive features, advanced engineering and rugged construction mean:

- Maximum Versatility
- Precise Mixing Control and Consistency
- Higher Output
- Faster Mixing Time

The #1 choice of bakers from coast to coast...you can count on it's quality and reliability!

## All Models 208V 3-Phase 60 Cycle (Other voltages available)

Model	Capacity*		Overall**			Bowl			Weight (lbs.)	Electrical		
	Breads	Bagels	Width (with Bowl)	Depth	Height	Width	Height	Top of Bowl to Floor		HP		Amps
	Flour/Dough	Flour/Dough								A	B	
80	100/160	80/120	29	43	48	28	14	33	858	6	6.75	19.4
100	130/208	100/150	29	43	48	28	16	35	924	7	7.75	22.5
130	150/240	120/180	33	54	51	31	17	35	1309	8	10.7	30.3
160	220/350	200/300	37	61	55	35	17	35	1550	14	16.7	47.3
200	250/400	220/330	37	61	55	35	19	36	1585	14	16.7	47.3
250	300/480	250/375	41	64	55	39	18	36	1804	14	16.7	47.3
300	350/560	300/450	44	68	55	43	20	38	1892	20	22.7	61.6

Dimensions in inches

**\*NOTE:** Mixers used for bagel dough are rated at low speed only. Operation at high speed will result in lower capacity and void the warranty.

**\*\*Machine width with bowl removed does not exceed 33" (for entry through 36" doorway).**

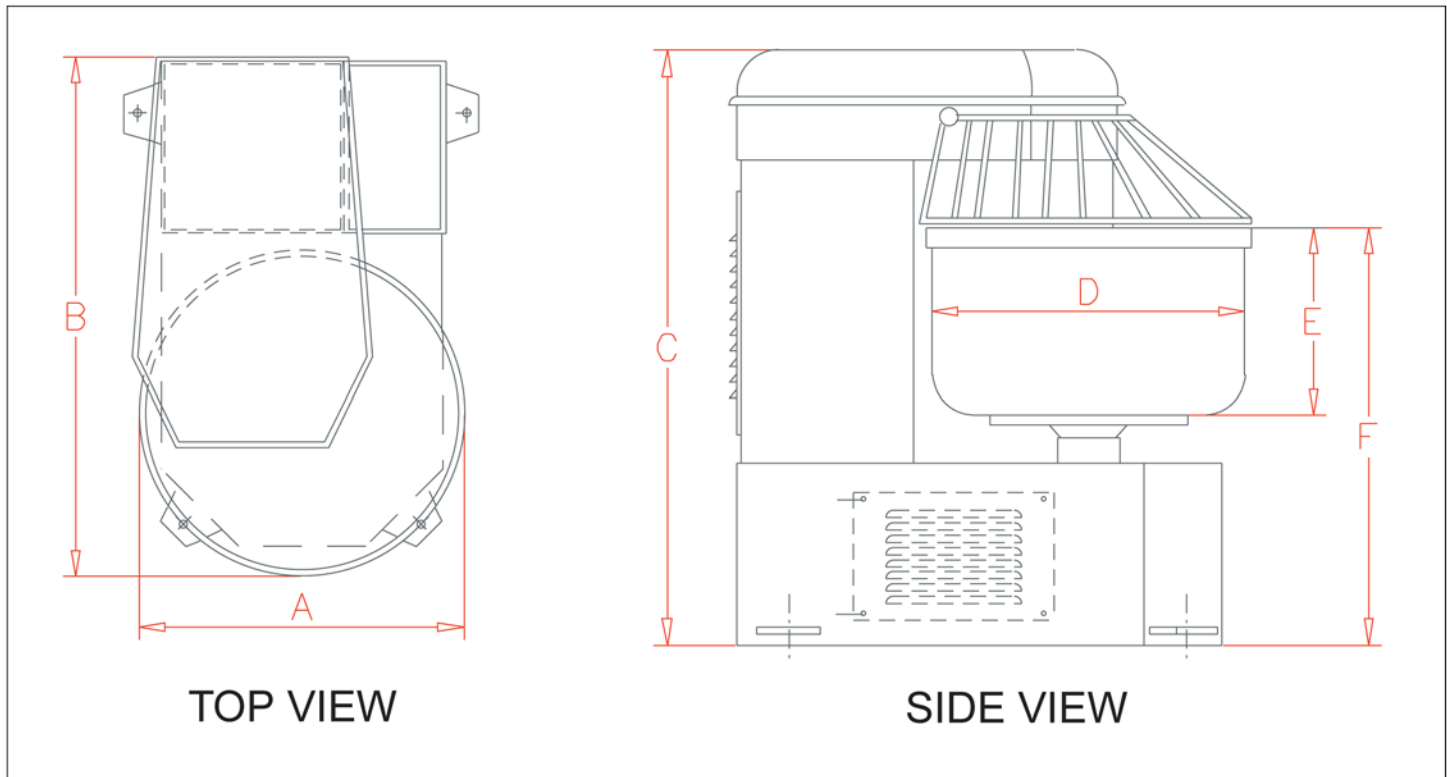

**NOTE:** Specifications are subject to revision and confirmation.