

Features

- ◆ 2-Speed Spiral and Bowl Drive
- ◆ Reversible Bowl Rotation
- ◆ Two Timers with Automatic Changeover
- ◆ Hi-Speed Lock Out Switch to Prevent High-Speed Operation
- ◆ Stainless Steel Bowl, Spiral Arm, Breaker Bar and Guard
- ◆ See-thru Bowl Guard with Safety Interlock Prevents Operation with Guard Open
- ◆ Belt Driven Arm and Bowl for Quiet Operation and Low Maintenance
- ◆ Hydraulic Lifting Device is Smooth and Reliable
- ◆ Dual Side Discharges at Various Heights for Discharge onto Bench or into Dough Hopper



The Tiltover Advantage

Now you can have all the advantages of the Empire Spiral Mixer and the ease of automatic dough discharge. Strong enough for bagels, gentle enough for delicate doughs, Empire Tiltover Spiral Mixers are available in a wide range of sizes and offer exclusive features, advanced engineering and rugged construction.

Coordinated 2-speed spiral and bowl rotation gives maximum control of ingredient blending, dough development and a better end product. The hydraulic lift system eliminates the need and cost of additional bowls or bowl hoist. From the control panel you can select right or left discharge at heights preset for machine hoppers, dough troughs or a workbench. Benefits include: **maximum versatility • higher output • faster mixing time • precise mixing control and consistency • quiet, reliable and safe operation.**

Technical Data

TSM-AR-0411

Model	Capacity*		Discharge Height		Overall Dimensions**				Weight lbs.	Electrical*** 208V (3 Phase 60HZ)		
	Breads	Bagels	Max.	Min.	Overall	Overall	Bowl	Overall		HP		Amps
	Flour/Dough	Flour/Dough	A	B	Width C	Depth D	Height E	Height† F		Spiral	Total	
160AR	200/320	150/220	72	52	45	77	40	114	3329	14	16.7	47.3
200AR	250/400	200/296	71	51	45	77	42	114	3484	14	16.7	47.3
250AR	300/480	250/370	70	50	45	79	42	116	3858	14	16.7	47.3
300AR	350/560	300/444	68	49	45	83	44	116	4035	20	23	61.6

All Dimensions in Inches

6/8/07

*Mixers used for bagel dough are rated at low speed only; operation at high speed will result in lower capacity and void the warranty.

**Doorway Span (required for delivery) = 87" x 47"

***Other voltages available

†Ceiling Height REQUIRED = 120" (lower heights by special order)

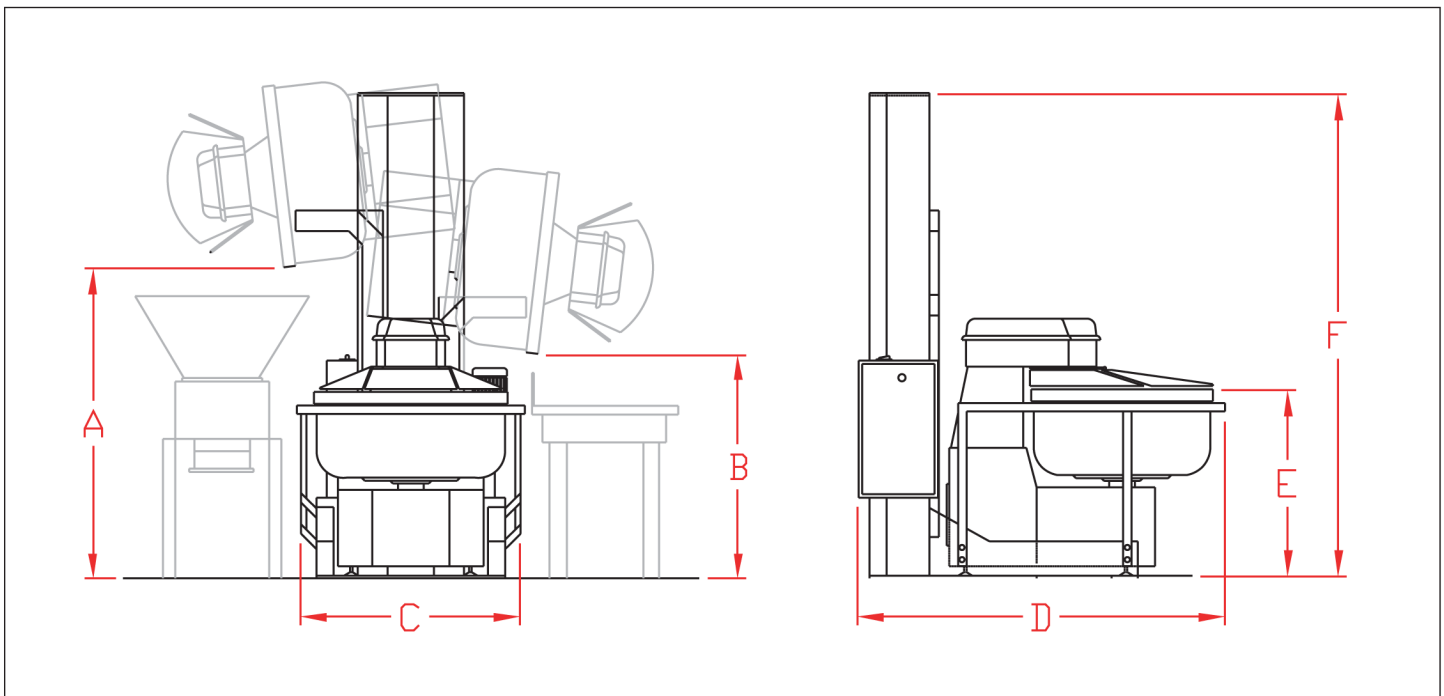

NOTE: Specifications are subject to revision and confirmation.



1C Enterprise Place, Hicksville, NY 11801-5356 ♦ Ph: (516) 681-1500 ♦ Fx: (516) 681-1510
 1-800-878-4070 ♦ www.empirebake.com ♦ Email: info@empirebake.com