

## FLOOR SHEETERS EMP-LAM



Folded for Easy Storage

### More Versatile Than a Swiss Army Knife!

**Empire's EMP-LAM Reversible Floor Sheeter** is the ultimate multi-task tool for your bakery. It's ideal for laminated dough, pie crusts, cookies, fondant, pet treats and so much more! Large diameter rollers and significant dough capacity will provide you with consistent, high quality production while the easy-to-read digital display allows for precise control over sheeting thickness. When you're finished for the day, removable polyethylene scrapers make cleaning a snap and its folding design and foot-lever activated rolling system make for easy storage. Include the optional cutting attachments to expand this sheeter's capabilities even further.

Clean design and rugged construction ensure years of trouble-free performance from **Empire's LAM Reversible Floor Sheeter**. With all of these benefits it's easy to see why the **EMP-LAM** is the must-have tool for your bakery!

### Standard Features

- ◆ Digital Sheeting Thickness Display
- ◆ 3 3/8" Diameter Sheeting Rollers
- ◆ 2 1/8" Maximum Roller Opening
- ◆ High Volume Sheeting Capacity
- ◆ Compact Design (tables fold up for storage)
- ◆ Removable Polyethylene Scrapers for Easy Cleaning
- ◆ Synthetic Fabric Belts
- ◆ Lever Operated Reversing Belts
- ◆ Mounted on Casters for Easy Mobility
- ◆ Flour Holder Built into Machine Casting
- ◆ Rolling Pins and Supports Included

### Accessories

- ◆ Dough Cutting Attachments
- ◆ Foot Pedal Controls

# Technical Data

## FLOOR SHEETERS EMP-LAM

Model	Working Dimensions			Stored Dimensions		Belt Width (E)	Roller Opening	Electrical		Net Weight
	Overall Length (A)	Width (C)	Height (D)	Length (F)	Height (G)			Connection	Power	
	in	in	in	in	in	in	in	V/Hz/Ph	Amps	
EMP-Lam 610	99.2	41.5	53.9	41.5	63.4	23.5	2.2	220/60/1	6	330
EMP-Lam 612	115.0	41.5	53.9	58.3	71.3	23.5	2.2	220/60/1	6	341
EMP-Lam 614	130.7	41.5	53.9	66.1	78.0	23.5	2.2	220/60/1	6	352
EMP-Lam 614-CA*	130.7	41.5	53.9	-	78.0	23.5	2.2	220/60/1	6	360
EMP-Lam 616	146.5	41.5	53.9	74.4	85.0	23.5	2.2	220/60/1	6	374
EMP-Lam 616-CA*	146.5	41.5	53.9	-	85.0	23.5	2.2	220/60/1	6	374
EMP-Lam 6514	130.7	45.3	46.0	63.6	78.1	25.6	2.2	220/60/1	8	380
EMP-Lam 6514-CA*	130.7	45.3	46.0	-	78.1	25.6	2.2	220/60/1	8	638
EMP-Lam 6516	146.5	45.3	46.0	72.0	84.8	25.6	2.2	220/60/1	8	594
EMP-Lam 6516-CA*	146.5	45.3	46.0	-	84.8	25.6	2.2	220/60/1	8	814

\* CA denotes models with optional Cutting Attachment. PLEASE NOTE: Models with cutting attachments do not have the ability to fold up for storage

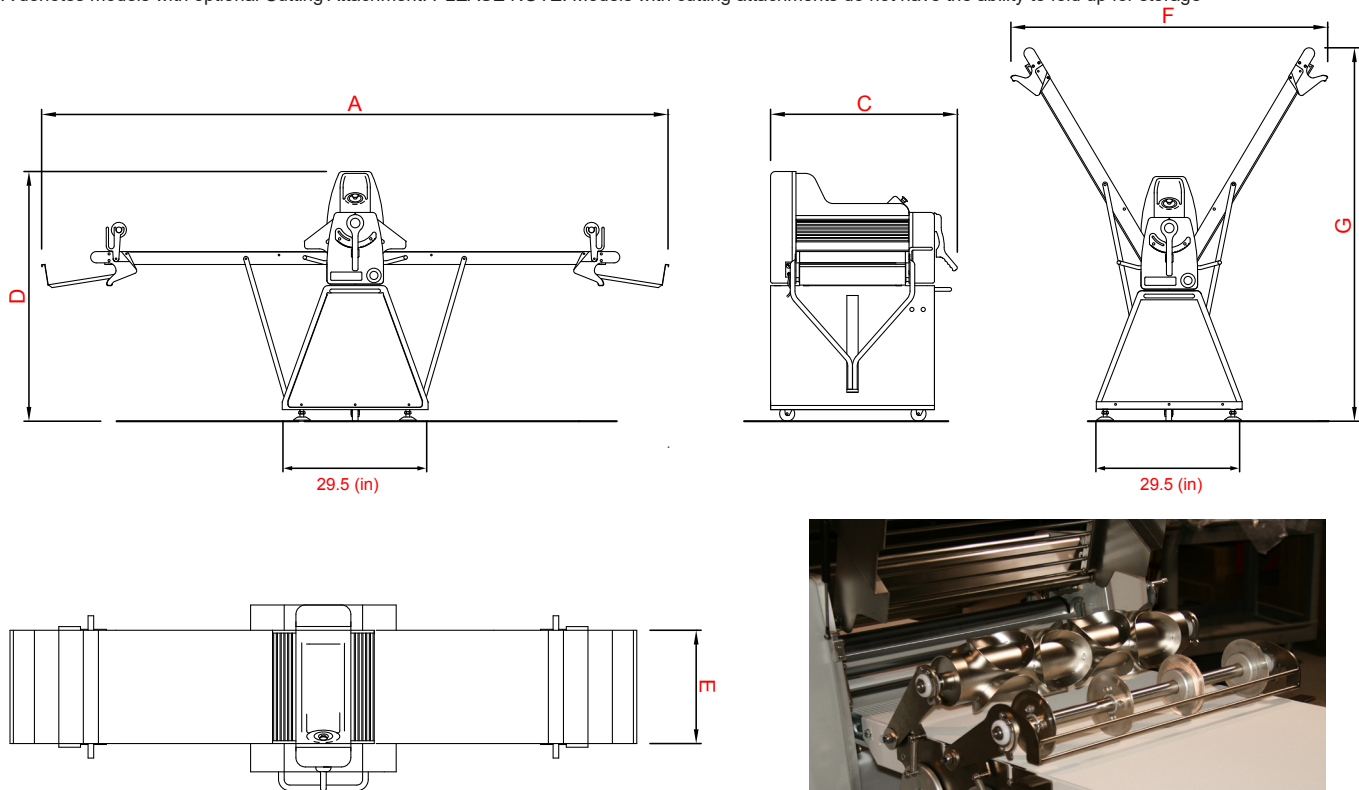

Optional cutting system.

### LIMITED WARRANTY

This product is warranted to the original purchaser to be free from material and workmanship defects. This warranty extends for a period of one (1) year from the date of purchase on parts and labor and 90 days on electrical components. For additional information or if you have any questions, please do not hesitate to contact us toll free at 1-800-878-4070.

Please note: It is our policy to continually improve our equipment. Therefore, we reserve the right to change specifications and/or design without notice.



1C Enterprise Place, Hicksville, NY 11801-5356 ♦ Ph: (516) 681-1500 ♦ Fx: (516) 681-1510  
1-800-878-4070 ♦ www.empirebake.com ♦ info@empirebake.com