

REMOVABLE BOWL LIFT **SRP**

Features

- ◆ The perfect compliment to your Empire Removable Bowl Mixer
- ◆ Forward tilting dump with Stainless Steel dough chute
- ◆ Easy-to-use electromechanical controls
- ◆ The durable hydraulic & chain lifting device is smooth and reliable
- ◆ Dumping heights from 51" to 134"
- ◆ All models comply with ETL standards for safety and sanitation
- ◆ 220V/3Ph/60Hz Electric (standard)
Other voltages are available

Options

- ◆ Optional Bowl Jog Motor available
- ◆ Bowl Scraper System available
- ◆ Safety Cage with External Controls



Need a Lift?

Enter the **SRP Removable Bowl Lift**, the complete solution for the elevation and dumping of dough for further processing. An ideal compliment to Empire's line of Removable Bowl Spiral Mixers, the **SRP Bowl Lift** is perfect for dumping into a variety of hoppers and automatic lines.

The heavy duty painted steel frame guarantees stability and durability, while the fast and quiet hydraulic system assures complete safety in handling and minimal maintenance.

Technical Data

REMOVABLE BOWL LIFT SRP

All Models 220V 3-Phase 60 Cycle (Other voltages available)

Model	Dimensions (in.)				Weight	Power
	Width (A)	Depth (B)	Overall Height (H1)	Dump Height (H2)		
	in	in	in	in	lbs	Amps
SRP-140	68.9	110.3	110.3	53.1	3065	10.1
SRP-180	68.9	110.3	126.0	68.9	3065	10.1
SRP-220	68.9	110.3	141.7	84.6	3065	10.1
SRP-260	68.9	110.3	157.5	100.4	3065	10.1
SRP-300	68.9	110.3	173.2	116.1	3065	10.1
SRP-340	68.9	110.3	189.0	131.9	3065	10.1



Optional Bowl Scraping Arm

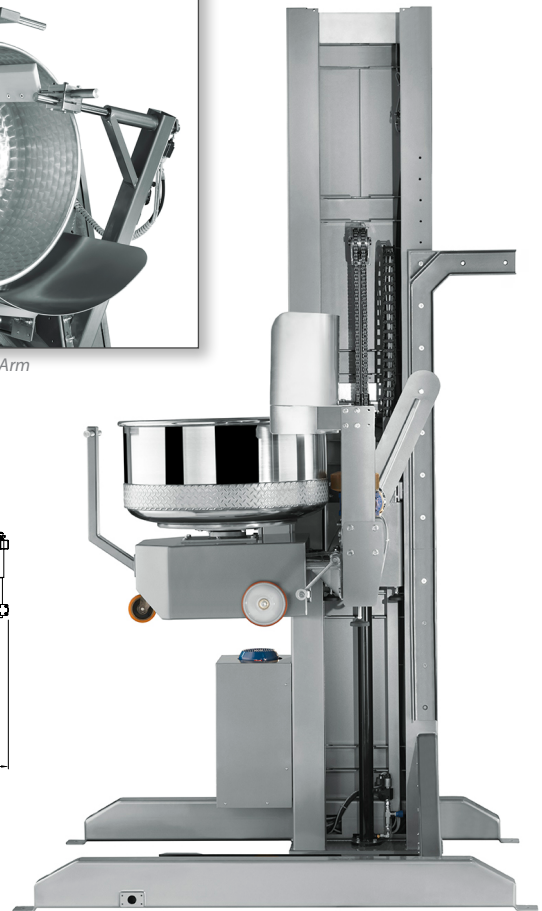
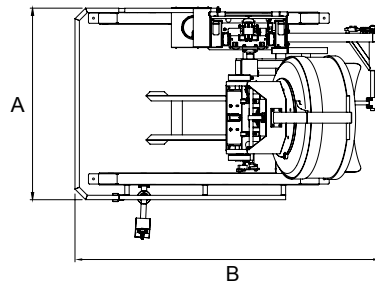
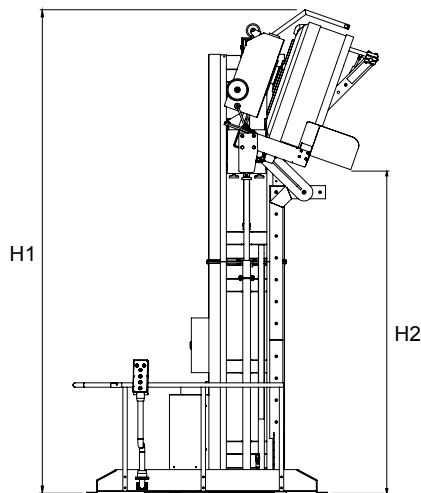

LIMITED WARRANTY

This product is warranted to the original purchaser to be free from material and workmanship defects. This warranty extends for a period of one (1) year from the date of purchase on parts and labor and 90 days on electrical components. For additional information or if you have any questions, please do not hesitate to contact us toll free at 1-800-878-4070.

Please note, specifications are subject to change without notice as we continually work to improve our equipment.



1C Enterprise Place, Hicksville, NY 11801-5356 ♦ Ph: (516) 681-1500 ♦ Fx: (516) 681-1510
1-800-878-4070 ♦ www.empirebake.com ♦ info@empirebake.com