

VOLUMETRIC DIVIDER/ROUNDER **SVP**

Features

- ◆ Divides and Rounds Dough from 0.7 oz - 9.9 oz.
- ◆ Double drum design for greater weight range
- ◆ Perfect for the production of buns, rolls, pita, tortilla and more
- ◆ Compact design ideal for wholesale production
- ◆ Can be used individually or inserted into a line.
- ◆ Adjustable internal flour duster
- ◆ Sturdy stainless steel structure with food safe plastic at dough contact locations.
- ◆ Production up to 6,000 pieces per hour
- ◆ Easy-to-use touch mechanical controls



Dividing & Rounding for High Production

The **SVP Automatic Volumetric Divider/Rounder** is designed for bakeries and pizzerias where high production and performance levels are required. This versatile machine can be used individually, with an automatic load or in a line with other machines.

Options & Accessories

- ◆ Optional connection point for additional equipment
- ◆ Motorized outfeed with pressure roller option

The **SVP Automatic Volumetric Divider/Rounder** partitions and rounds doughs automatically by setting the parameters with its touch screen control panel without having to replace or swap parts. Performance is guaranteed by its high quality stainless steel and food safe plastic materials that give the machine great functionality, longevity, reliability and quality.

Technical Data

VOLUMETRIC DIVIDER/ROUNDER SVP

Model	Working Dimensions			Divisions per hour	Basis Weight (oz)		Weight in	Electrical (220V/3Ph/6_0Hz) Amps
	Width in	Width w/ Belt in	Height in		Divide/Round (see options below)	Divide Only		
SVP1	29.5	64.9	66.9	1,500	0.7 - 8.8	10.6 - 24.7	1168	34
SVP2	29.5	64.9	66.9	3,000	0.7 - 8.8	10.6 - 24.7	1168	34
SVP3	29.5	64.9	66.9	4,500	0.4 - 4.6	10.6 - 24.7	1168	34
SVP4	29.5	64.9	66.9	6,000	0.4 - 1.6	10.6 - 24.7	1168	34

1 ROW max 1,500 pcs/h		2 ROWS max 3,000 pcs/h		3 ROWS max 4,500 pcs/h		4 ROWS max 6,000 pcs/h	
SVP1-SA		SVP2-SA		SVP3-SA		SVP4-SA	
oz. min	oz. max	oz. min	oz. max	oz. min	oz. max	oz. min	oz. max
0.7	2.1	0.7	2.1	0.7	2.1	0.4	1.1
1.2	3.5	1.2	3.5	1.2	3.5	0.6	1.6
1.4	4.6	1.4	4.6	1.4	4.6		
3.5	7.1	3.5	7.1				
5.3	8.8	5.3	8.8				
SVP1-DA		SVP2-DA		SVP3-DA			
0.7	3.9	0.7	3.9	0.7	3.9		
1.1	5.3	1.1	5.3	1.1	4.6		
1.4	7.1	1.4	7.1				
2.8	9.9	2.8	9.9				
SVP1-DA-R1		SVP2-DA-R1		SVP3-DA-R1		SVP4-DA-R1	
17.6	24.7	17.6	24.7	17.6	24.7	17.6	24.7
SVP1-DA-R2		SVP2-DA-R2		SVP3-DA-R2		SVP4-DA-R2	
10.6	17.6	10.6	17.6	10.6	17.6	10.6	17.6

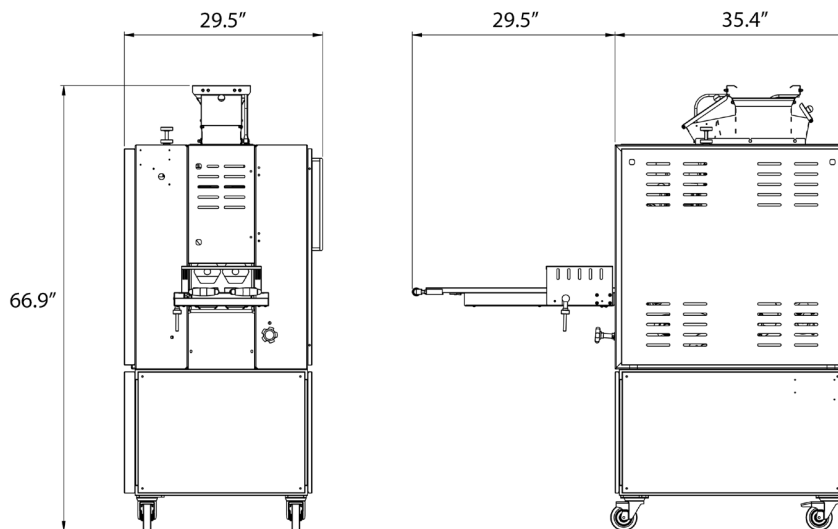

LIMITED WARRANTY
 This product is warranted to the original purchaser to be free from material and workmanship defects. This warranty extends for a period of one (1) year from the date of purchase on parts and labor and 90 days on electrical components. For additional information or if you have any questions, please do not hesitate to contact us toll free at 1-800-878-4070.

Please note, specifications are subject to change without notice as we continually work to improve our equipment.



1C Enterprise Place, Hicksville, NY 11801-5356 ♦ Ph: (516) 681-1500 ♦ Fx: (516) 681-1510
 1-800-878-4070 ♦ www.empirebake.com ♦ info@empirebake.com