

REVOLVING TRAY OVEN EMP-LC

Features

- ◆ Aluminized Steel Interior Walls and Roof
- ◆ Stainless Steel Exterior Side and Back Walls
- ◆ Digital Controls with Timer
- ◆ High Intensity Interior Lights
- ◆ Solid Metal Trays with Back Riser
- ◆ Automatic Loading/Unloading Tray Stop
- ◆ Natural Gas Fired Burner complete with Flame Safeguard
- ◆ Voltage - 120 VAC - 20 Amp
- ◆ Automatic/Manual Tray Rotation
- ◆ Stainless Steel Vertical Sliding Door
- ◆ Pre-Insulated Wall and Roof Panels
- ◆ Interior Constructed of Aluminized Steel for Increased Reflectivity
- ◆ Louvered Front Removable Doors for Better Ventilation
- ◆ Various Tray Configurations
- ◆ All Bearings maintenance free Graphite bushings
- ◆ High Density Insulation & Heavy Duty Base Construction
- ◆ Tray Stabilizers ensure a level bake.
- ◆ Drive components, Burner controls and Electrical are all front accessible
- ◆ Built in exhaust hood
- ◆ On/Off Burner, Light and Fan Controls
- ◆ Shipped knockdown

Accessories

- ◆ Power Exhaust Hood complete with motor (Ventilator and switch - piping not included)
- ◆ Steel Screen or Lava Baking Stone Trays
- ◆ Self Generating Steam Unit



Experience the Revolution

The newly redesigned **Empire Revolving Tray Oven** is art in motion! A clean, solid design seamlessly combines advanced technology and sturdy, dependable construction. Featuring a large capacity baking chamber and reliable, low-maintenance burner system, the **Empire Revolving Tray Oven** is perfect for baking everything from bagels, breads and rolls to pastries, cakes, cookies and more! It's even great for roasting meats and other food service applications.

The new **Empire Revolving Tray Oven** is direct-fired and available in capacities from 8-36 pans. It comes outfitted with an integrated Type II exhaust hood standard, upgradeable to a Type I. An optional integrated steam system is also available.

Outfitted with a bagel kettle and trough, the **Empire Revolving Tray Oven** is the must-have bagel oven for bagel shops across the country!

Technical Data

REVOLVING TRAY OVEN EMP-LC

Model	Description	Overall Dimensions			Shelf Dimensions	BTU	Electric (120V/60Hz/1Ph)
		Width (A)	Depth (B)	Height (C)			
		in	in	in			
EMP-LC-4-8G	4 Shelf, 8 Pan	72	87	84	38 x 26	150,000	20
EMP-LC-4-12G	4 Shelf, 12 Pan	90	87	84	54 x 26	200,000	20
EMP-LC-4-16G	4 Shelf, 16 Pan	108	87	84	72 x 26	250,000	20
EMP-LC-4-20G	4 Shelf, 20 Pan	126	87	84	90 x 26	300,000	20
EMP-LC-6-18G	6 Shelf, 18 Pan	90	104.5	91.3	56 x 26	300,000	20
EMP-LC-6-24G	6 Shelf, 24 Pan	108	104.5	91.3	74 x 26	350,000	20
EMP-LC-6-30G	6 Shelf, 30 Pan	126	104.5	91.3	92 x 26	400,000	20
EMP-LC-6-36G	6 Shelf, 36 Pan	144	104.5	91.3	110 x 26	450,000	20

UTILITIES

- ◆ Gas Connect Point: 1" pipe size
- ◆ Natural gas @ 5"-14" w.c. when firing
- ◆ Propane gas @ 13"-14" w.c. when firing
- ◆ Power: 120V/60 Hz/1 phase/20 amp
- ◆ Hood: Suitable for Type II applications.
- ◆ Connection size and cfm requirement vary by model.
- ◆ All require 0,6" w.c. static pressure drop @ hood connection.
- ◆ Type II Hood: For heat, steam, odors and products of combustions (Standard)
- ◆ Customer to supply duct and ventilator fan per local code.
- ◆ If accepted by local building officials, suitable for connection to Type B pipe except when products of baking are grease laden.
- ◆ Oven control panel includes exhaust hood push button with contractor (10 amp 120V output for fan operation.)

INSTALLATION

A factory technician or factory authorized service technician MUST supervise and approve any installation. Purchaser is responsible for all installation costs and for providing:

- ◆ All local service connections per local code electricity, gas and ventilation are responsibility of purchaser
- ◆ Disposal of packaging material
- ◆ Installation suitable for concrete floors. Wood floors require and insulated riser, (not included in oven purchase)

NOTE: Floor should be level within 1/8" per foot for proper installation.

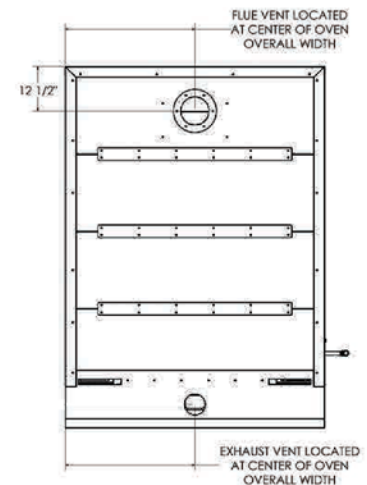
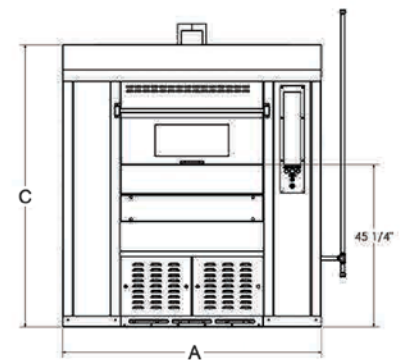
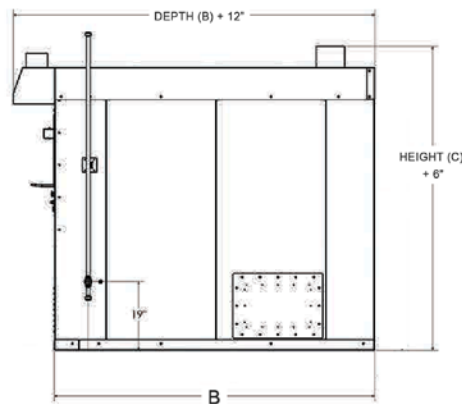

LIMITED WARRANTY

This product is warranted to the original purchaser to be free from material and workmanship defects. This warranty extends for a period of one (1) year from the date of purchase on parts and labor and 90 days on electrical components. For additional information or if you have any questions, please do not hesitate to contact us toll free at 1-800-878-4070.

Please note, specifications are subject to change without notice as we continually work to improve our equipment.



1C Enterprise Place, Hicksville, NY 11801-5356 ♦ Ph: (516) 681-1500 ♦ Fx: (516) 681-1510
 1-800-878-4070 ♦ www.empirebake.com ♦ info@empirebake.com