



# SINGLE BANK BAGEL MACHINE **EMP1-2A**



## World's Favorite Bagel Machine

The Empire Automatic Bagel Machine is time proven. It's fast, strong, reliable and is easily adapted for the production of mini, regular and bull bagels at up to 3,600 pieces per hour. The divider has a scaling range of 1 to 12 ounces and may be used independently to divide many types and textures of dough. Our variable knife speed assures you of the proper dough piece shape for all sizes and weights of your product. The bagel former is designed to work in conjunction with the divider, but may also be hand fed.

## Features

- ◆ Produces up to 3,600 Pieces/Hour
- ◆ Rotary Knife Action - No Piston or Messy Oil Clean Up
- ◆ No Heat Transfer from Machine to Dough
- ◆ Knife is Teflon Coated (No Oiling Necessary)
- ◆ 4 Foot Infeed Conveyor for High Capacity
- ◆ Variable Speed on Knife Allows you to Adjust Dough Piece Shape for the Best Possible End Product
- ◆ 20 Inch Turntable for Easy Accessibility and Panning
- ◆ Easily Adjusted Pressure Plate
- ◆ Mounted on Casters for Easy Movement & Cleaning
- ◆ Cutaway Frame Allows Easy Clean-Up

# Technical Data

## SINGLE BANK BAGEL MACHINE EMP1-2A

Model	Weight lbs	Electrical		
		VOLTAGE	HP	AMPS
EMP1 (Dough Divider)	550	220v / 3Ph / 60Hz	1/2	2.2
EMP2A* (Bagel Former)	300	220v / 3Ph / 60Hz	1 1/2	4.6

\*EMP2A bagel former available as single phase on special order only.



SIDE VIEW

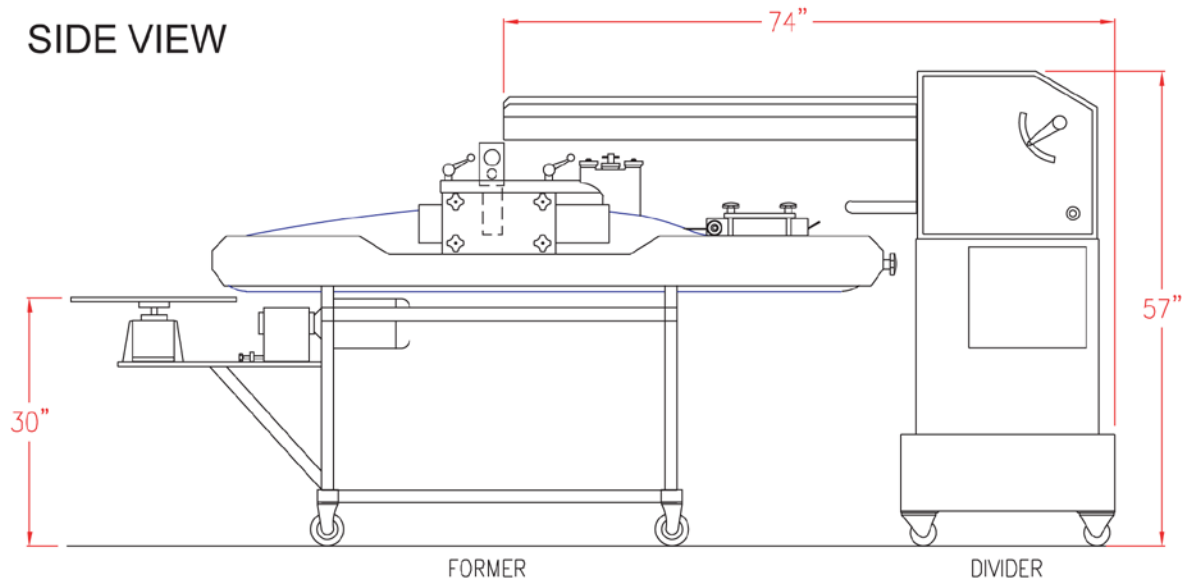

TOP VIEW

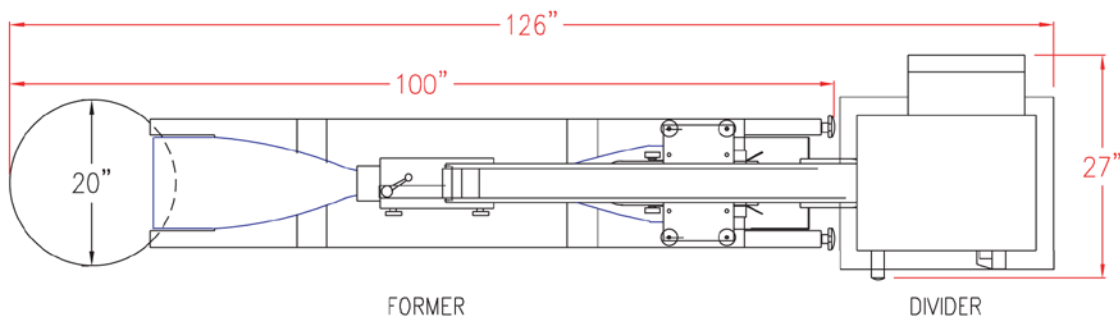

### LIMITED WARRANTY

This product is warranted to the original purchaser to be free from material and workmanship defects. This warranty extends for a period of one (1) year from the date of purchase on parts and labor and 90 days on electrical components. For additional information or if you have any questions, please do not hesitate to contact us toll free at 1-800-878-4070.

*Please note, specifications are subject to change without notice as we continually work to improve our equipment.*



1C Enterprise Place, Hicksville, NY 11801-5356 ♦ Ph: (516) 681-1500 ♦ Fx: (516) 681-1510  
 1-800-878-4070 ♦ www.empirebake.com ♦ info@empirebake.com